

Flashing: Valleys, Walls, Chimneys, etc.

6

YOUR OBJECTIVE:

To learn CertainTeed-recommended flashing installation methods and ways to apply shingles at the valleys.

FLASHING INSTALLATION

As you can well imagine, a good place for a leak to develop is anywhere the roof joins with walls and chimneys. To help prevent these leaks from occurring, corrosion-resistant metal flashing is typically applied. Metal flashing is effective, because when properly installed, it can help accommodate roof, chimney, wall, or structural movements due to settling, expansion, and contraction.

ROOF FLASHING WORKS LIKE SHINGLES: it overlaps and sheds water. Flashing is always constructed in a system to work with the effect of gravity. When correctly designed and installed, flashing can only be defeated by water running uphill. This can happen in the presence of snow, ice or wind-driven rain.

Thus, all flashing systems recommended in this chapter should be reviewed by installers with an eye to local weather extremes, especially the aforementioned elements. The best backup security for flashing systems at this time is the presence of waterproofing shingle underlayment beneath it. However, local experience may call for other flashing modifications to withstand weather-related conditions.

Flashing typically consists of (1) "step" flashing, which is attached to the roof, (2) "cap" flashing, which is attached to the chimney or a wall (Figure 10-2), (3) "drip edge" flashing, and (4) "valley" flashing. Step flashing is sometimes called "base flashing" and cap flashing is sometimes called "counter flashing." Often, exterior wall siding serves as cap flashing.

DRIP EDGE

Drip edge is the simplest flashing. It is used at the rakes and eaves. There are two basic styles of drip edge, generally known as C and "Extended." C-style drip edge does not have an overhang, while the "Extended" profile has a hemmed overhang at the edge of the roof deck.

On rakes, drip edge is installed on top of the underlayment to prevent wind-driven rain from getting beneath it. On eaves, it is installed beneath the underlayment to allow water to shed smoothly off the roof if it gets under the shingles.

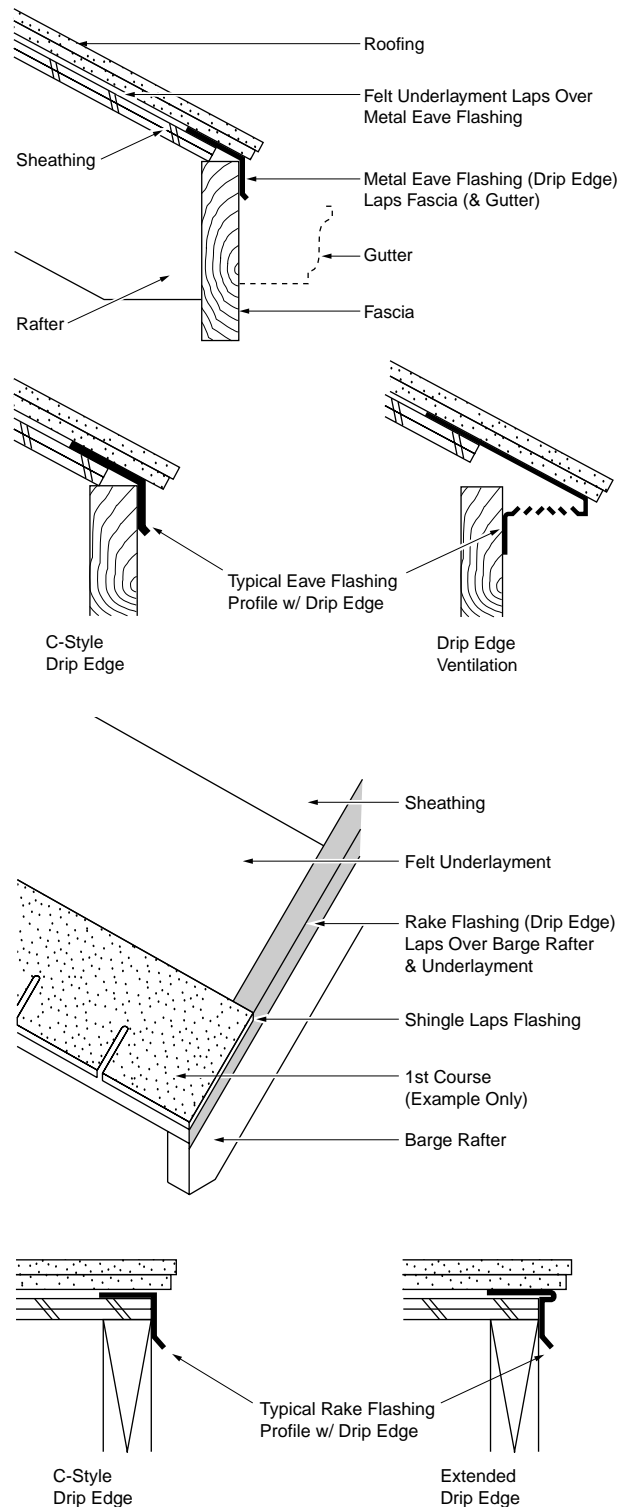

Figure 6-1: Typical eaves and rake flashing profiles with drip edge.

Here Are Some Tips

In a roof-over, you need to expose step-flashing before installing the second layer of shingles. If the second layer is just cut around the object, and the apron flashing is not brought out on top of the new shingles, then the original step flashing drains onto the apron and down between the layers. After several years, the deck is saturated and rotting. Opening up the flashing the right way is a "pain," but it must be done. Thanks to Tim Mosher from Lima, OH. Tim recently repaired the bottom corners of 8 dormers on his parent's roof where the flashing was "shingled-over"... no wonder he sent us this tip!

5. Apply an additional row of shingles over the metal flashing strip, trimmed to match the vertical width of the metal flashing strip on the shingle surface. Fasten shingles with face nails sealed over with a small dab of roofing cement.
6. Next, if there is siding, bring it down over the vertical part of the step flashing to serve as cap flashing. Do not nail the siding into the vertical flashing.

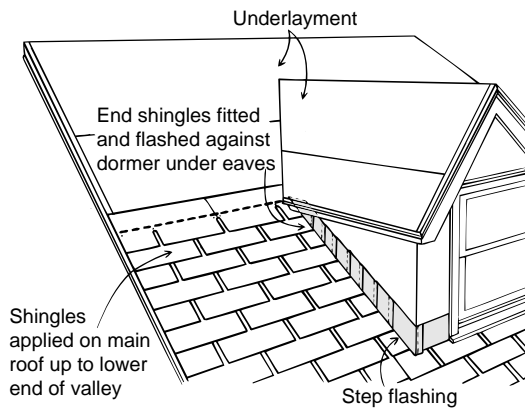

Figure 6-4: Front/side wall flashing.

7. If the vertical front wall meets a sidewall, as in dormer construction, cut the front flashing so that it extends at least 7" around the corner. Then continue up the sidewall with step flashing as described earlier. A good quality caulk, or asphalt roofing cement, may be useful to fully seal behind corner joints, if they will not be soldered.

SOIL STACKS AND VENT PIPES

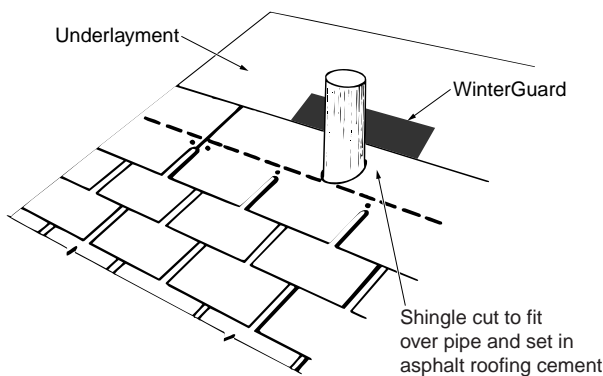

Figure 6-5: Cutting shingle to fit around vent pipe.

- ★ Practically all homes have circular vent pipes or ventilators projecting through the roof. Before installing the flashing, apply WinterGuard around the penetration as follows: Cut a square piece of WinterGuard. Center the piece over the pipe's top and cut an X into

the WinterGuard slightly smaller than the inside diameter of the pipe's opening. Remove the release film, then lower the WinterGuard around the pipe and seal it to the deck. After that, install the shingles up to the vent pipe. Then cut a hole in the shingle that will go over the pipe and install the shingle, setting it in asphalt plastic cement. Next, place a preformed flashing flange, sized to fit snugly over the pipe, over the vent pipe and set it in asphalt roofing cement. Be sure the flange is seated squarely on the roof.

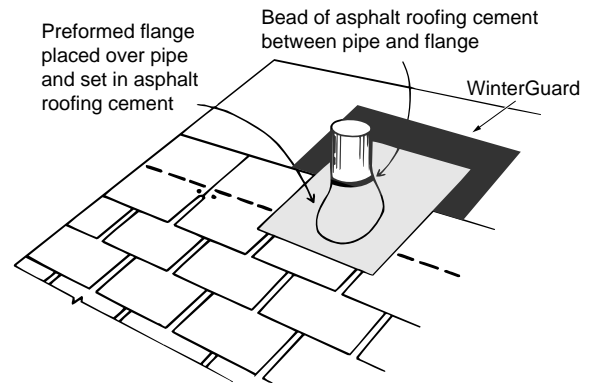

Figure 6-6: Placement of flange over vent pipe.

After the flashing is in place, continue applying the shingles. Cut the shingles in the succeeding courses to fit around the pipe, and embed them in asphalt roofing cement where they overlap the flashing flange. The completed installation should appear as shown in Figure 6-7, with the lower part of the flange overlapping the lower shingles, and the side and upper shingles overlapping the flange.

Follow the same procedure where a ventilator or exhaust stack is located. If the ventilator, exhaust stack, or soil pipe is near a ridge, bring the shingles up to the protrusion from both sides and bend the flashing flange over the ridge to lie in both roof planes, overlapping the roof shingles at all points. Ridge shingles are then positioned to cover the flange. Embed the ridge shingles in asphalt roofing cement where they overlap the flange.

Flexible neoprene boots are also commonly used to flash around vent pipes.

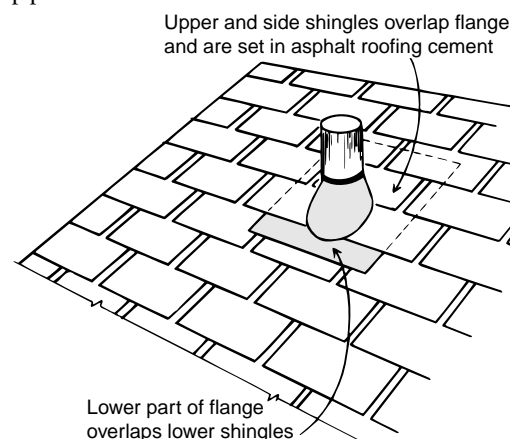

Figure 6-7: Applying shingles around flange.

Here's a Tip... Thoroughly clean the groove with water to remove all dust. Wet-cleaning of the masonry joint is the best way to remove dust that can prevent proper adhesion of caulking material. Compressed air, vacuuming, or use of a wire brush are not as thorough as cleaning with water. Allow to dry completely.

FLASHING AROUND CHIMNEYS

Because chimneys are usually built on an independent foundation that is separated from the main house foundation, the chimney can move independently of the rest of the house. To allow for chimney/deck movement, the base flashing is secured to the roof deck and counter or cap flashing is secured to the chimney. When movement occurs, the step-cap flashing system will act as a moveable joint.

In moderate to severe climates that experience heavy snow, ice or high winds, waterproofing shingle underlayment such as CertainTeed WinterGuard™ is recommended for installation around the base of the chimney. Prime the masonry surfaces and run the waterproofing underlayment up the sidewall 3" or 4". It is a flexible material that will accommodate the differential movement of chimney and deck.

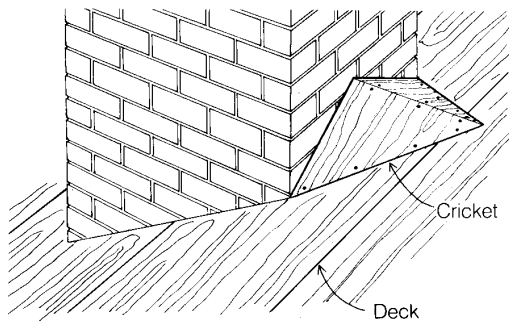

Figure 6-8: Chimney through the roof deck.

For chimneys projecting through the roof surface, we recommend that a "cricket" be installed at the intersection of the uppermost face of the chimney and the roof deck. The cricket, sometimes called a wood saddle, is an important element in preserving the integrity of the flashing that will be installed because it prevents the build-up of ice and snow at the rear of the chimney and diverts water runoff around the chimney. It also prevents water from "ponding" and backing up under the shingles during winter freeze/thaw periods.

The cricket should be in place before roofing installation begins, because all roofing materials from the felt underlayment to the roofing shingles are applied over it.

A cricket consists of two triangular sections of plywood joined to form a level ridge that extends from the centerline of the chimney back to the roof deck. Nail the sections to the deck and to each other along their meeting edge, customizing as necessary to get a tight fit.

Crickets are recommended when a chimney is wider than 24", the roof pitch is 6/12 or greater, and where snow and ice accumulations are likely.

Apply shingles up to the front vertical edge of the chimney. Apply base flashing against the front vertical wall as shown in Figure 6-9. Apply step flashing to the side and back walls as described previously for side walls.

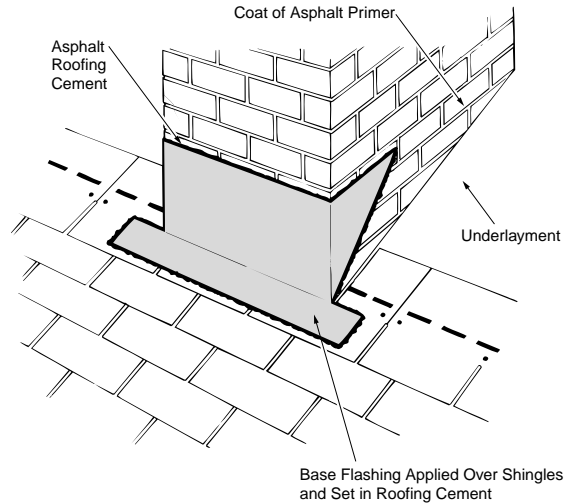

Figure 6-9: Chimney base flashing application.

Cap flashing techniques will vary with the type of chimney finish, such as stucco or brick. In general, for positive exclusion of water from the chimney joint, begin by setting the metal cap flashing, typically copper, aluminum, or galvanized, into the brickwork as shown in Figure 6-10. This is done by cutting out a mortar joint to a depth of 1½" and inserting the bent edge of the flashing into the cleared joint. Once in place and being under a slight amount of spring tension, the flashing cannot be dislodged easily. Refill the joint with portland cement mortar, silicone caulk, or use a soft metal wedge and polyurethane sealant. Finally, bend the flashing down to cover the base flashing, or pre-bend it so it will lie snugly against the masonry.

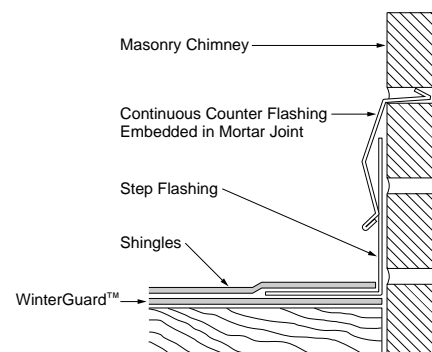

Figure 6-10: Through-wall metal counter flashing embedded in masonry.

Use one continuous piece of cap flashing on the lowermost and uppermost sides of the chimney as shown in Figure 6-11. On the sides of the chimney, use several pieces of similar-sized flashing, trimming each to fit the particular location of brick joint and roof pitch. Start the side units at the lowest point and overlap each at least 3" side-to-side. If the sides of the chimney have a continuous surface, such as a stucco finished chimney, use a continuous piece of cap flashing.

Here's a Tip... When flashing at a wall or chimney where the two points meet, place an extra piece of step flashing on each side with a horizontal cut about 3" at the bend on both pieces. Interlock them together for an extra water-tight fit. (Thanks to Marty Holley from Gabanna, OH.)

Here's a Tip... If flashed incorrectly, corner locations are the most likely areas for leaks to occur.

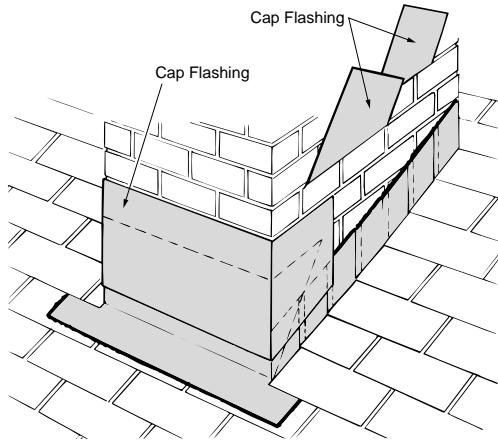

Figure 6-11: Applying cap flashing.

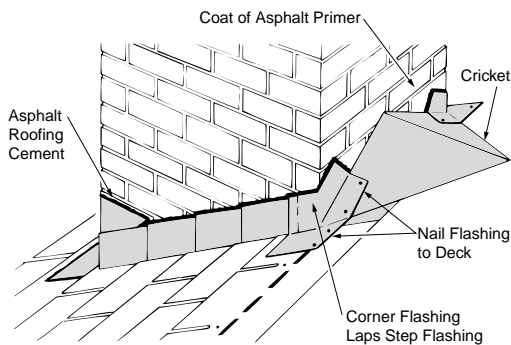

Figure 6-12: Applying corner flashing.

If a cricket is not used (Figure 6-13), the vertical sidewall base flashing should be pre-bent and extend up the chimney at least 6" and up the roof deck at least 18", with appropriately formed sides and corners. The first course of shingle material to cross the roof deck on the uppermost side of the chimney should be trimmed back a minimum of 2" from the chimney vertical flashing bend and set in asphalt plastic cement. This 2" setback allows quick water drainage, prevents water from working up under the shingles, and promotes a natural cleaning of debris from the high side of the chimney.

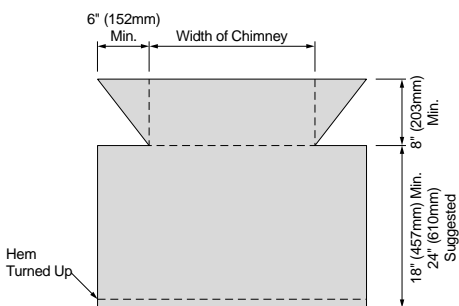
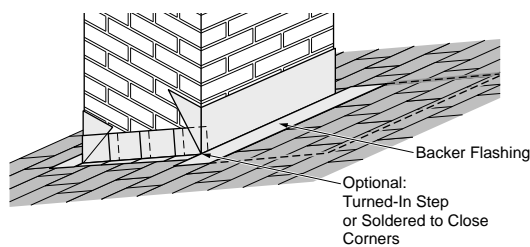

Figure 6-13: Example of sheet metal back flashing for upslope portion of masonry chimney.

MASONRY CHIMNEYS AND WALLS

CONTINUOUS COUNTER FLASHING: This optional counter flashing technique uses a continuous metal piece instead of the typical staggered (stepped) counter flashing along the side of a chimney or wall with mortar joints. It is an alternative to stepped counter flashing, which can lead to water leaks along the vertical joints in high wind or permit the entry of wind-driven, fine-grained snow. With continuous counter flashing, the apron flashing is continuous over the shingles and up the masonry wall. The vertical wall portion is then covered with counter flashing (Figure 6-14).

BEFORE CUTTING THE "REGLET":

1. Mount a guide or ledger on the side of the chimney or wall to be cut.
2. With a dry masonry or diamond wheel on a circular saw or grinder, cut a groove (also known as a "reglet" or "raggle") in a straight line parallel to the roof slope. The groove should be a minimum of 1" deep into the masonry (1¼" to 1½" is preferred).

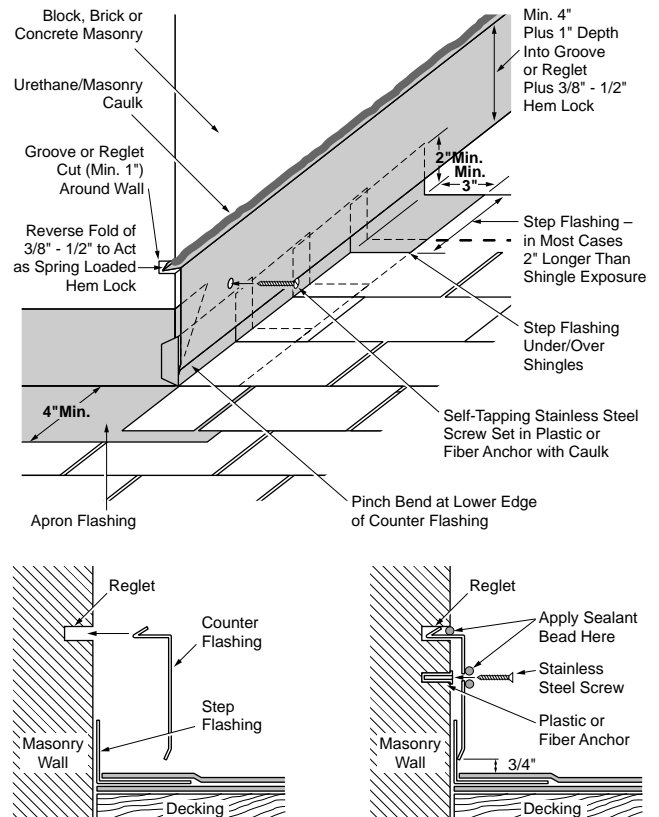

Figure 6-14: Continuous counter flashing against masonry chimneys and walls.

Apply shingles and step flashing to the roof at the joint with the masonry chimney or wall. Pay particular attention to any metal corner bends and joints (Figure 6-14).

Choose the appropriate length and width dimensions of metal to be used for continuous counter flashing. Plan your sequence of bends in advance, and form the metal. A metal brake is preferred for accurate bends. Also, don't forget to allow extra length to accommodate each bend (obviously, this depends on the thickness of the metal used).

Here's a Tip... Pre-measure all counter flashing dimensions to allow a 3/4" separation from the step flashing corner bend to the bottom edge of the counter flashing. This distance allows sufficient space to account for applied shingle thickness over the step flashing. Pre-fit pieces as necessary for corners, etc.

IN FORMING THE METAL CONTINUOUS COUNTER FLASHING, PAY PARTICULAR ATTENTION TO:

1. The reverse fold of 3/8" to 1/2", which will act as a spring-loaded hem lock in the groove.
2. The depth of metal into the groove.
3. The pinch bend, which will ensure a tight fit against step flashing and add rigidity to continuous metal counter flashing.

Run a bead of sealant or caulking into the reglet prior to installing the counter flashing. Choose a sealant/caulking that is specifically designed for use with masonry. Urethane-based materials are well-suited for masonry/metal applications.

Set the continuous metal flashing into the reglet with the pre-applied sealant/caulk and allow to cure. After this sets up, run a final bead of sealant/caulk on the exposed area of the reglet to seal the metal-to-masonry joint.

DORMER

The junction of a dormer with a sloping roof requires a base or apron flashing below the window sill. *Figure 6-15* illustrates the two systems that are usually encountered.

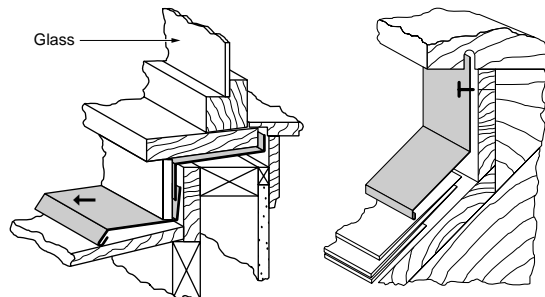

Figure 6-15: Two examples of base flashing below the window sill of a dormer.

SINGLE PITCH RIDGE

Occasionally, shingles are installed on a single pitch ridge. *Figure 6-16* illustrates how to finish off flashing on a single pitch ridge.

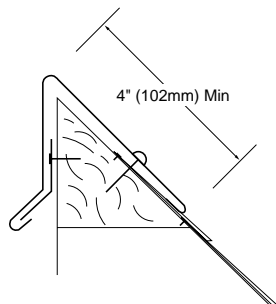

Figure 6-16: Topping off flashing on a single pitch ridge.

GALVANIC ACTION

Dissimilar metals in contact with each other will undergo a reaction in the presence of water. This is called galvanic action, which results in the corrosion of one of the metals. The following is the galvanic scale. When any two of the metals noted are in direct contact, the metal lowest on the list will corrode. The farther apart the metals are on the list, the faster corrosion occurs.

GALVANIC SCALE

Lowest	Resistance to Galvanic Corrosion →	Highest
Aluminum		
Zinc		
Steel		
Stainless Steel		
Tin		
Lead		
Brass		
Copper		
Bronze		

For example, if you attach copper with steel nails, the nails will corrode. To prevent dissimilar metals from contacting each other, they must be isolated with underlayment, bituminous paint or another non-conducting material.

METAL VALLEY MATERIALS

The materials listed below are considered "equivalent" to 16 oz. copper in open valley applications.

Material	Gauge*	Nominal Thickness
Galvanized Steel	26	0.022 in. (0.56mm)
Aluminum	22	0.025 in. (0.63mm)
Terne (Painted)	22	0.023 in. (0.58mm)
Stainless Steel	24	0.024 in. (0.61mm)
Copper (16 oz/ft ²)	23	0.022 in. (0.56mm)

*Units differ by material type.

Here's a Tip... To ensure a weather-tight seal and professional application, put a small amount of sealant/caulk in the masonry anchor hole and around the outside of the counter flashing hole before inserting the screw.

Here's a Tip... In a closed-cut valley, run 1 course of the "cut side shingles" through the valley under the "uncut shingles" where the bottom edge of the 2nd course of the cut shingles intersects the 1st course of the uncut shingles. A natural offset for the valley cut is produced. (Thanks to David Hennage from Fairmount, MN.)

VALLEY INSTALLATION

Open valleys are required for CertainTeed Custom Lok™ 25 because it has a unique design that does not lend itself to a closed-cut or woven valley application. Open valleys are **strongly recommended** for Grand Manor, Carriage House, Centennial Slate™, LandMark TL, Presidential Shake and Presidential TL. Because of the thickness and multiple-layer construction of these types of shingles, they are not designed to conform easily with the angle or shape of a valley. Note that when installing open valleys, only **metal** valleys are recommended. Mineral-surfaced roll roofing is not considered to be sufficiently durable to last for the warranted life of today's shingles. Moreover, there is no warranty on mineral-surfaced rolls.

CLOSED-CUT VALLEY APPLICATION

This is the valley application preferred by CertainTeed for all installations except as noted above. Prior to shingle application, line the valley by centering and applying 36" wide self-adhering CertainTeed WinterGuard™ Waterproofing Shingle Underlayment, or its equivalent, directly to the deck.

Begin the closed-cut valley application method using shingles in the following manner:

1. Lay the first shingle course along the eaves of the first roof plane and across the valley, onto the adjoining roof plane, at least 12". Press the shingles well into the valley prior to fastening.

NOTE: The shingles on the deck with the least area of watershed are the shingles which should be applied first, to go under the other shingles on the adjoining deck. The shingles on the adjoining deck (the deck with the greatest amount of watershed) are the shingles which should be cut.

2. Follow standard fastening instructions, with the exception that fasteners may not be installed within 6" of the valley's centerline.
3. Follow the same procedure for succeeding courses, going up the valley from one side.
4. Apply the first course of shingles along the eaves of the adjoining roof area, extending it over previously applied shingles. Follow the same procedure for succeeding courses. When complete, snap a chalk line 2" back from the centerline of the side just installed (which is the greater watershed). Neatly cut 2" back from the centerline, following the chalk line as a guide.
5. Cut 2" diagonally off the upper corner of each trimmed shingle (at an approximate 45° angle) to direct water into the valley. Take care not to cut into the shingles below.

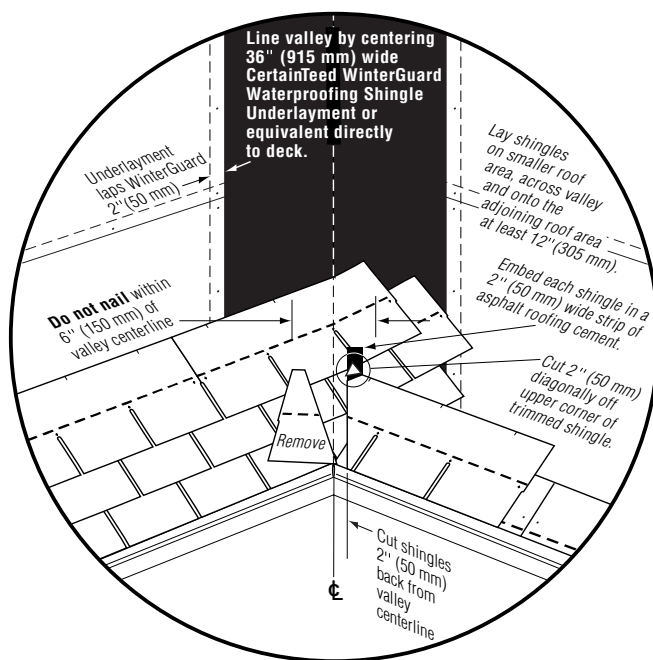
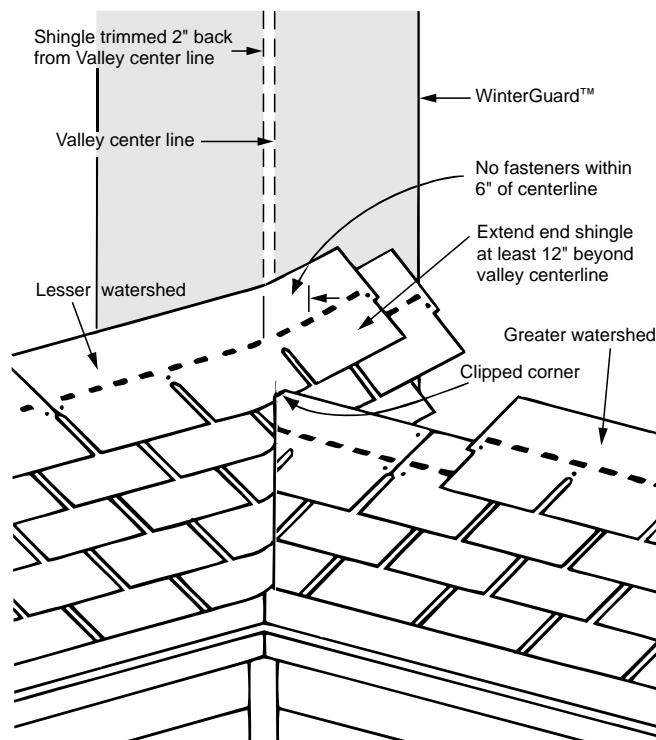

Figure 6-17: Closed-cut valley application.

Here's a Tip... When trimming shingles in a closed-cut valley, use a book blade and place a scrap shingle under the area to be trimmed to prevent damage or scoring of the valley shingles beneath..

Here Are Some Tips...

When cutting shingles at valleys, I have found that using medium size tin snips works better than using a hook knife. (Thanks to Barry Butrymowicz from Mountain, WI.)

When using the alternate closed valley application in cold weather, I band nail all triple layered areas with 2" nails for a secure application. (Thanks to Brent Schneider from Oshkosh, WI.)

ALTERNATE CLOSED VALLEY APPLICATION

Prior to shingle application, line the valley by centering and applying 36" wide self-adhering CertainTeed WinterGuard™ Waterproofing Shingle Underlayment, or its equivalent, directly to the deck. Begin the valley application using shingles in the following manner:

1. Lay the first shingle course along the eaves of the first roof plane and across the valley, onto the adjoining roof plane, at least 12". Press the shingles well into the valley prior to fastening.
NOTE: Always start applying the shingles on the deck with the least area of watershed.
2. Follow standard fastening instructions, with the exception that fasteners may not be installed within 6" of the valley's centerline.
3. Follow the same procedure for succeeding courses, going up the valley on the first side.
4. On the adjoining roof plane, snap a chalkline 2" back from the valley centerline. Apply shingles "vertically" facing the valley and 2" back from the valley centerline (use chalkline as a guide.)
5. Apply the shingles on the adjoining roof plane by positioning the lower left corner of the shingle of each row 2" back from the centerline (flush with the edge of the vertical shingle.) and over the top of the "vertical shingle." See Figure 6-18.

CAUTION: This application cannot be used with shingles that have cut-outs, such as a typical 3-tab strip shingle.

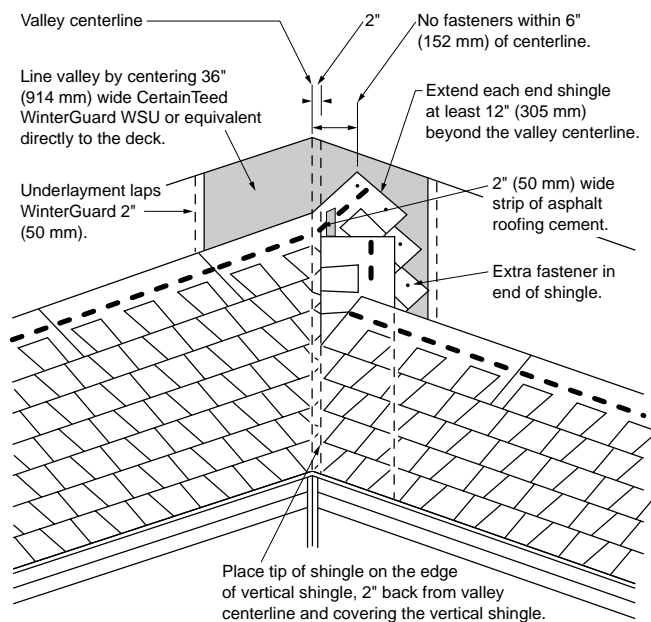

Figure 6-18: Alternate closed valley application.

MAKING THE JUDGEMENT CALL

Making decisions about cutting shingles in valleys often requires some careful thinking. Here are two "tough" calls:

1. If a 10/12 roof section forms a valley with a 4/12 roof section, and the 10/12 section is one-third the area (water volume) of the 4/12 section, you should cut the shingles on the 10/12 side.
2. If an 8/12 roofing section forms a valley with a 10/12 roofing section and the 8/12 roof has one-third the area (water volume) of the 10/12 section, put the cut on the 8/12 side.

WOVEN VALLEY APPLICATIONS

The valley flashing should already be in place. Shingles on the intersecting roof surfaces may be applied toward the valley from both roof areas simultaneously or each roof area may be worked separately up to a point about 3' from the center of the valley and the gap closed later.

Regardless of which procedure is followed, apply the first course along the eaves of one roof area up to and over the valley with the last shingle extending at least 12" onto the intersecting roof. Then apply the first course onto the intersecting roof along the eaves and extend it across the valley over the top of the shingles already crossing the valley and at least 12" onto the other roof surface. Apply successive valley shingles over each other as shown in (Figure 6-19). Press each shingle tightly into the valley and follow the same nailing procedure as the closed valley.

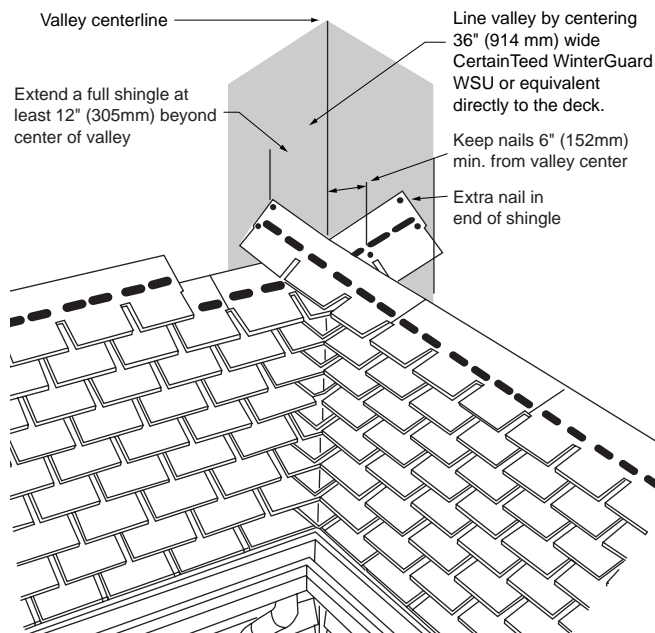

Figure 6-19: Woven Valley Application.

Here's a Tip... In open valleys, after you strike your 3" chalk lines, use the top edge of a shingle as a straight edge for your hook blade cuts. Your cuts will be straighter and you can trim three shingles at a time. (Thanks for this tip go to Kirk Kapel of Cleveland, Ohio)

**Here Are
Some Tips...**

Always carefully remove about 4" of the release tape from the back edge of shingles to be cemented down in asphalt roofing cement. This is to assure a watertight seal at open valley joints.

At the gutter, when preformed "W" style valleys are used, close off the open "V" by installing a small cap with pop rivets. (Thanks for this tip go to James J. Testaguzza of Bexley, Ohio.)

OPEN VALLEY APPLICATIONS

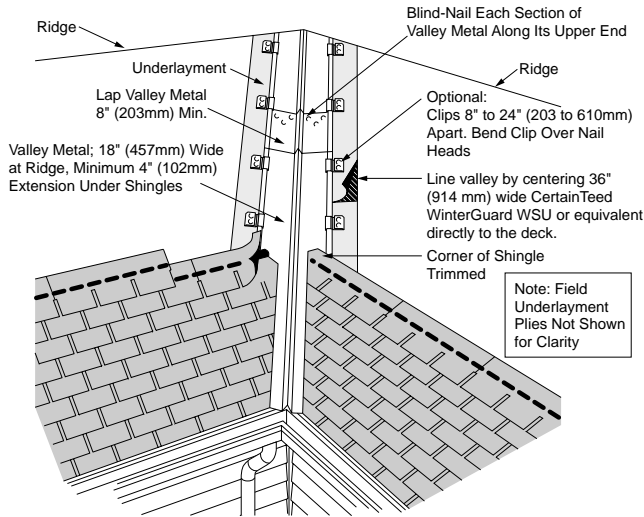

Figure 6-20: Typical open valley attached by cleats.

1. Apply a 36" piece of WinterGuard™ Waterproofing Shingle Underlayment, or its equivalent, up the center of the valley. WinterGuard is applied directly to the deck. An alternative for WinterGuard is mineral-surfaced roll roofing. If shingle underlayment is used on the remainder of the roof, it should overlap the WinterGuard by 4".
2. Next, apply an 18" – 20" wide sheet of metal valley flashing over the WinterGuard in 8' to 10' lengths. Use a narrow band of roofing cement to fasten shingles that lap the metal. Preformed "W" style valleys are preferred.

CAUTION: Due to the expansion and contraction, a granular-surfaced valley liner under a metal flashing can cause abrasion to the metal from the friction. Alternatives to consider include sand or film-surfaced liners.

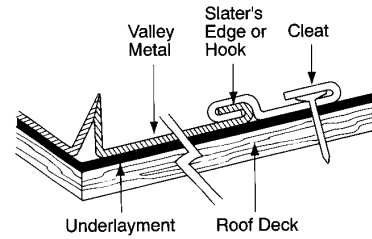

Figure 6-21: Secure metal valley flashing with metal cleats.

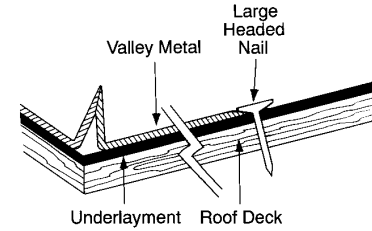

Figure 6-22: Secure metal valley flashing with large-headed nail.

3. Secure the metal flashing every 24" along both edges either with metal cleats or large-headed nails. If using large-headed nails without cleats, place the shanks immediately adjacent to the metal edge so as not to restrict the movement of the metal (Figure 6-22).
4. If you need to use more than one piece of metal flashing for a valley, the high piece must overlap the lower piece by at least 4". Because of expansion and contraction of the two metal sheets, do not drive fasteners through both sheets in the overlapping areas.
5. Strike chalk lines 3" from the valley centerline, on each side of the metal valley. As shingles are applied, trim them back to the chalk lines. Use a buffer beneath the shingles to be trimmed to avoid scoring the metal valley liner with the knife blade.
6. Set the valley edge of each shingle in a 3" wide band of asphalt roofing cement (ASTM D4586 Type II).

CAUTION: In some areas of the country it is common to start the application of shingles at the valley centerline. This method is not approved for Super Shingle® products due to the possibility that objectionable patterns may result in the finished roof.

Here's a Tip... Although many roofing manuals call for a traditional tapered valley (taper out 1" for every eight feet), CertainTeed recommends a straight open valley for composition shingles (3" exposure on each side of the centerline), because debris is less likely to become trapped in this low profile valley and because it makes a good appearance.

Here Are Some Tips...

Use caulks and sealants designed for the materials involved. Urethanes are suited for metal and masonry applications. SBS, SBR or rubber-based caulks are ideal for shingles and metal flashing. CertainTeed FlintBond™ is an SBS adhesive.

When reroofing, always check the existing flashing for cracks and other breaks. Repair or replace damaged or weak flashing before reroofing. To judge whether the flashing should be repaired or replaced, ask yourself whether the existing flashing will last at least 20 years. If not, replace it.

Before putting step flashing in place, bend it "open" a little so it will sit tight against the wall and be easier to work around. (Thanks to Jacob Church from Moscow, ID.)

ROOF PITCH TRANSITIONS

The flashing used for pitch transitions is essentially the same whether the steep pitch is on the high side, as in a transition to a porch, or on the low side, as on a mansard roof. The problem area is the termination of the lower course of shingles. Face nailing is necessary. Therefore, the flashing must lay under the shingles of the high slope, and lap the fasteners on the face of the terminated shingle in the course below the transition. Figures 6-23-A and B illustrate two ways to apply flashing at roof pitch transitions.

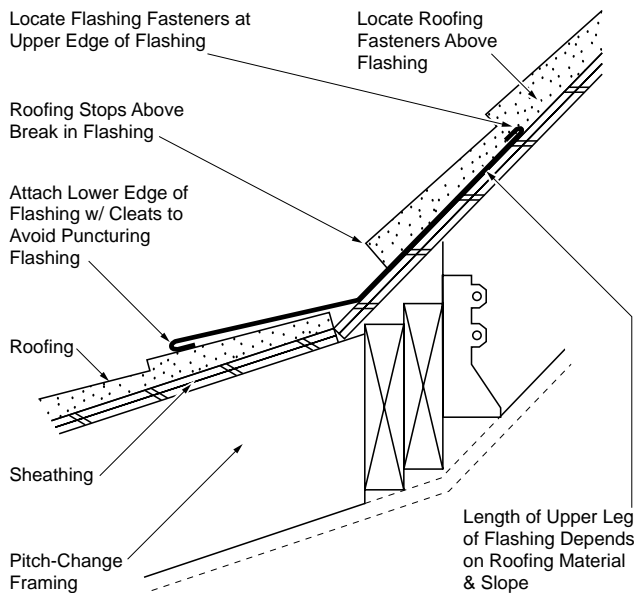

Figure 6-23-A

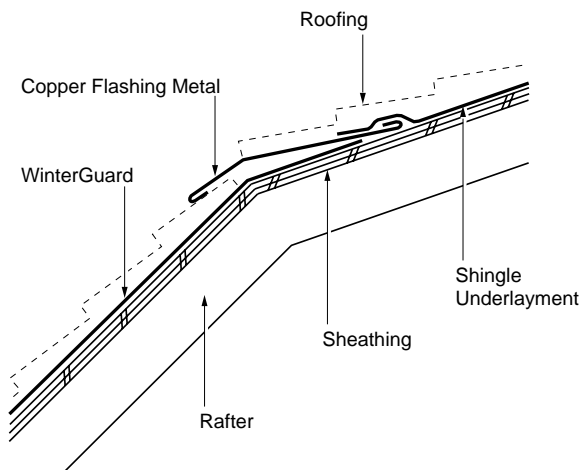

Figure 6-23-B

TWO METHODS OF APPLYING ROOFING MATERIALS AT THE ROOF PLANE CHANGE OF A GAMBREL ROOF

- SHINGLES ONLY:** Measure and adjust shingle application exposure over the last 6 to 8 feet of the lower roof to have the last shingle course exposed 4½" to 5" for 12" x 36" shingles or 7½" to 8" for 18" x 36" shingles. Gently bend and fasten these last shingles on the upper roof using roofing nails and on the lower roof with asphalt roof cement. If necessary, mechanically hold the lower portion of the shingles in place using small head siding nails (aluminum, painted in a matching color). Caution: Laminated and other stiff shingles may crack or buckle when applied in this fashion. If warming the shingles does not help, consider using the second method described below.
- DRIP EDGE OR GUTTER:** Apply shingles on the lower roof plane up to the joint and cut off excess shingle material flush to the deck joint. Apply a waterproof type underlayment, such as WinterGuard™, over the joint in the deck planes to help provide a waterproof barrier. The waterproofing underlayment should be applied directly to the upper deck plane and overlap the shingles on the lower deck plane by about 5". Install a 1" x 6" painted fascia board, (the waterproofing underlayment must be totally covered by the fascia board), at the very top of the lower roof and then install either drip edge or gutter onto the fascia. Apply shingles to the upper plane per standard application technique, letting the starter and first course shingles over hang the drip edge or gutter about ½" to ¾". Refer to Figure 6-24 below.

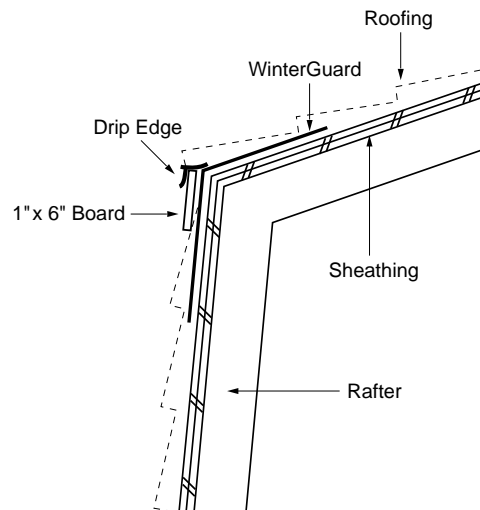

Figure 6-24

★ COMMON ROOF DECK SEPARATION JOINT

For dwellings with a common roof deck covering multiple units or owners, such as townhouses, duplexes, twin or row homes where only a sector of the common-roof is being replaced and the other portion will remain, the separation joint in the diagram below can be used. As the name implies, this separation joint delineates two different units/owners or roofing materials on the same roof deck and is similar in construction to that of an Open Metal Valley.

Cut the existing roof materials the length of the separation line. On the side where the existing roof is not being replaced, carefully remove sufficient roof material to allow the application of a 36' wide piece of WinterGuard to the roof deck, centered along the separation line.

Apply "W" style metal with outside edges rolled for a Slater's Hook over the WinterGuard and centered on the separation line from bottom to top. The metal must be at least 18" wide and is typically applied in 8' to 10' lengths to allow for expansion and contraction. When overlapping more than one length of metal, the high piece of metal must overlap the lower piece by 4" or more. Fasten the metal to the deck with clips installed 8" to 24" apart.

On the side where the existing roof is being replaced, apply new roof material. On the side where the existing roof is not being replaced, trim and reapply the previously removed roofing materials; if they are not reusable, apply similar new roofing material to match the existing roof. On both sides, the roofing materials are installed butted up against or close to the "raised peak" in the metal all the way up to the roof.

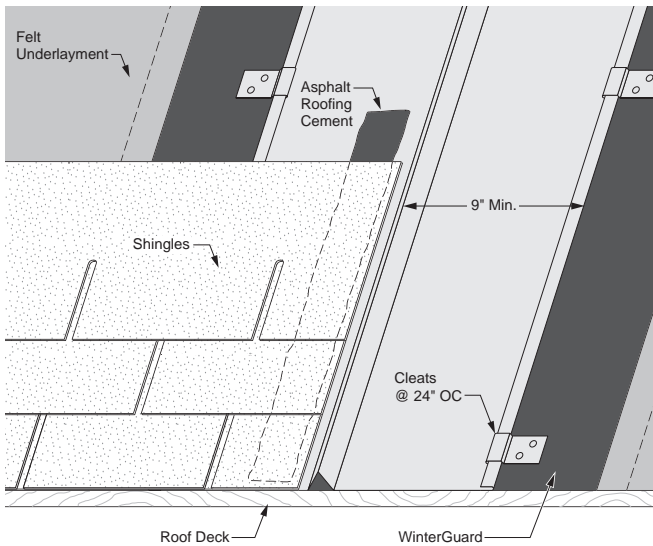

Figure 6-25

SKYLIGHTS

Many skylight designs are being sold. Most provide their own instructions for flashing the curb on which the skylight is mounted. The skylight curb is flashed much like a chimney. Install adhered waterproofing underlayment around the entire deck and bring the underlayment up onto the curb. An apron flashing with a hemmed lower edge is installed on the base. Step flashing is installed on the sides; base flashing is installed upslope, holding one course of shingles away from the curb to encourage rain to wash away dirt and debris. The skylight itself provides the counter flashing or cap.

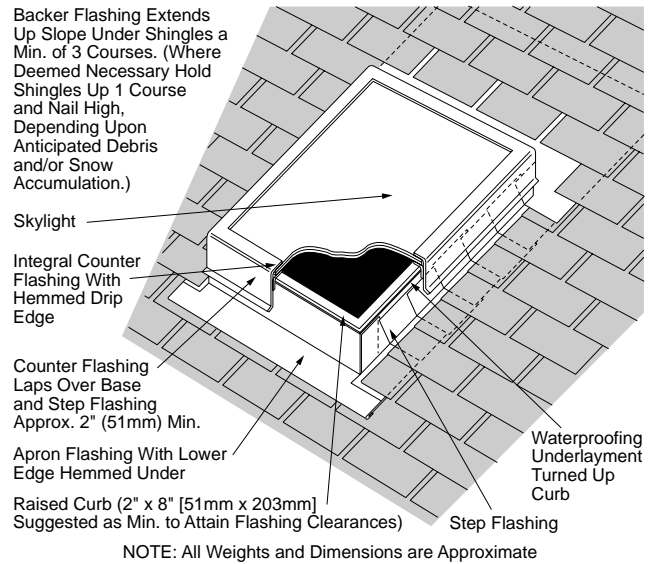

Figure 6-26: Basic sheet metal components used at skylight.

HEMMED EDGES

Hemmed edges are used on most metal flashing systems. The hem or fold makes the flashing strong at the hem and helps control water flow. The hem can be turned up or down. Hems turned up are used at the high edge of flashing installed around roof penetrations, such as skylights, soil pipes and chimneys. Uprturned hems are also used on the roof side of continuous sidewall flashing and on the vertical edge of open metal valleys. An upturned hem creates an air gap that resists the capillary migration of moisture from the metal to the roofing. They should never be hammered flat. Uprturned hems also serve as hooks for attaching cleats. Downturned hems are used when flashing is lapped over the top of roofing or other materials, such as skylight glass.

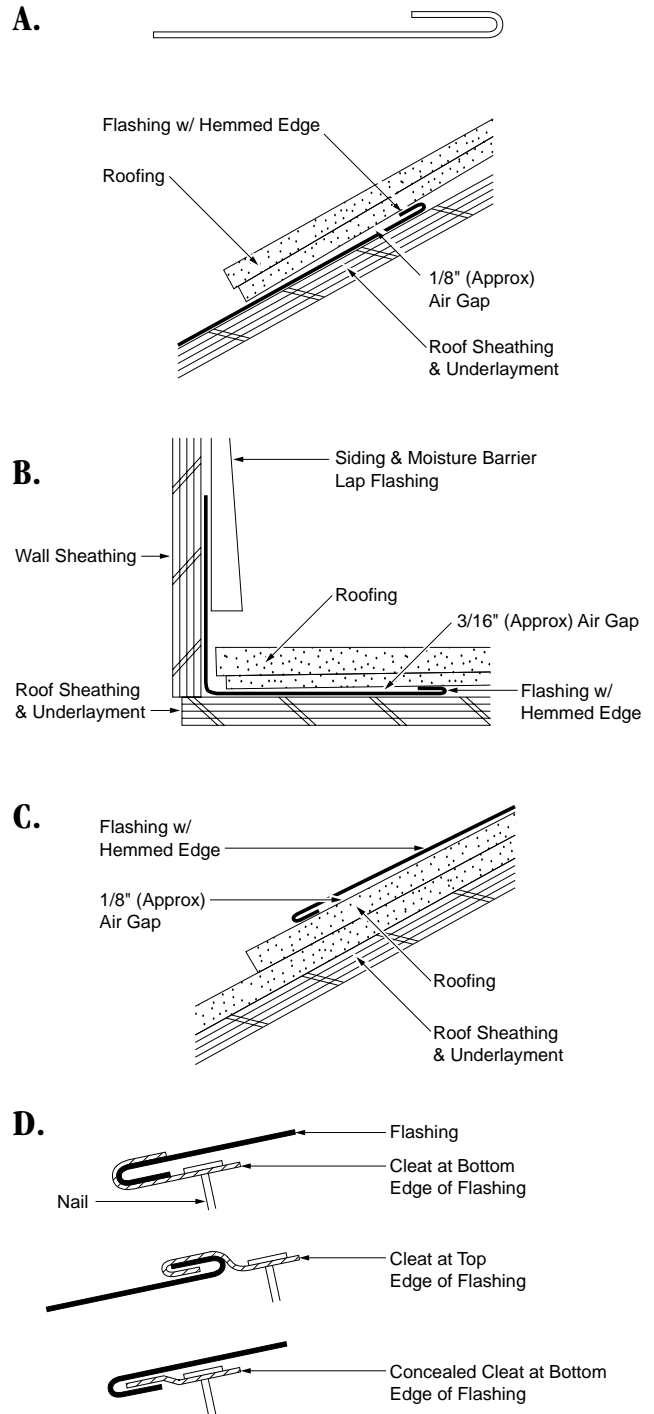

Figure 6-27: The hemmed edge is a very important detail for roof flashing.

Here's a Tip... You can prevent a possible leak by allowing the metal valley to overhang the fascia board. Hold the 3" marks parallel to the valley center – that is, the point where the shingles stop – even with the fascia boards at the top roof edge. This gets the water out past the fascia board (Figure 6-28). (Thanks for this tip go to John Berman of Pashtigo, Wisconsin.)

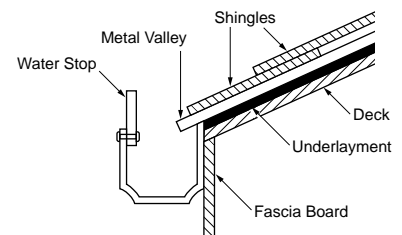

Figure 6-28: Valley side view